

- NOTE:
1. All m.s. steel to be painted with two (2) layer of anti rust paint
 2. All concrete to be grade 25.

TYPICAL CROSS SECTION
scale 1:100

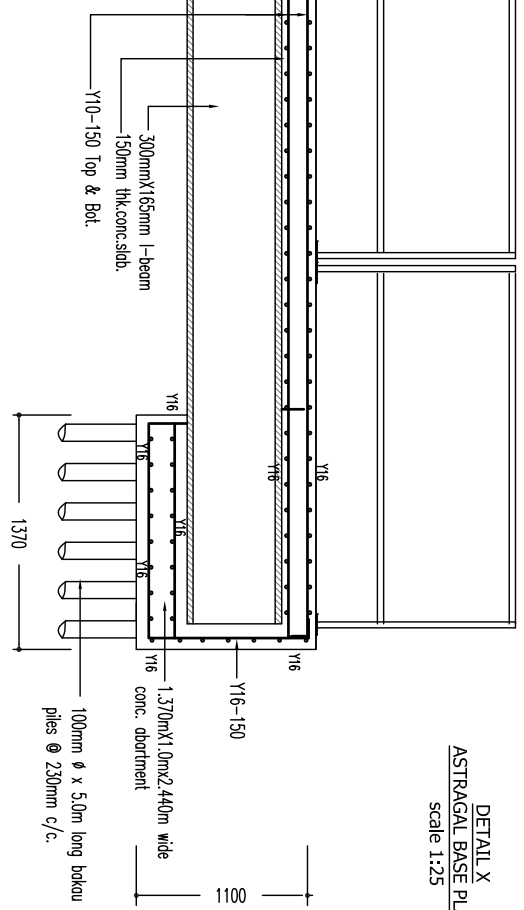
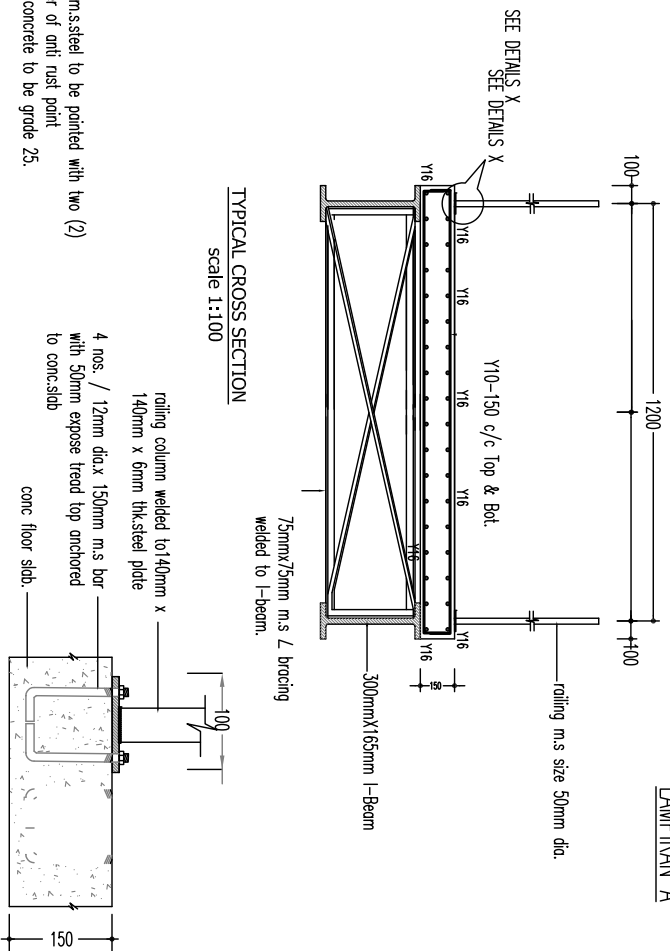

| | | | |
|---------|----------------|--------|--------|
| BUTIRAN | META / FIKSIAN | TAMBAH | TAMBAH |
|---------|----------------|--------|--------|

NIKAM PELAN YANG BERSEKUTAN
DIPALAM KONTROK NO:

| | | | |
|---|---|---|---|
| JABATAN PENGAIRAN DAN SALIRAN, NEGERI PULAU PINANG | JABATAN PENGAIRAN DAN SALIRAN, NEGERI PULAU PINANG | JABATAN PENGAIRAN DAN SALIRAN, NEGERI PULAU PINANG | JABATAN PENGAIRAN DAN SALIRAN, NEGERI PULAU PINANG |
| TAMBAH | TAMBAH | TAMBAH | TAMBAH |
| DI REVISI/DITUKAR | DI REVISI/DITUKAR | DI REVISI/DITUKAR | DI REVISI/DITUKAR |
| DI LUKIS ULANG | DI LUKIS ULANG | DI LUKIS ULANG | DI LUKIS ULANG |
| DI SEMAK ULANG | DI SEMAK ULANG | DI SEMAK ULANG | DI SEMAK ULANG |

DETAILS OF I-BEAM CROSSING
WITH CONCRETE SLAB.